

# LED Indoor Luminaires

## Ceiling Mount – Multi Linear Pendant

### 120-277VAC / 60Hz

Model #: SYDPxxLAJUDxxLNR3

### Safety Precautions

- Read all safety precautions and installation instructions carefully before installing or servicing this fixture. Failure to comply with these instructions could result in potentially fatal electric shock and/or property damage.
- It is recommended that a qualified electrician perform all the wiring. This fixture must be wired in accordance with all national and local electrical codes.
- Do not handle any energized fixture or attempt to energize any fixture with wet hands or while standing on a wet or damp surface or in water.
- This fixture is designed for use in a 120-277VAC / 60Hz circuit. The fixture is compatible with Triac (forward-phase or leading edge) / ELV (reverse phase or trailing edge) and 0-10V dimming circuit.
- Make sure that the power source conforms to the requirements of the fixture. (See labels on the fixture housing).
- To reduce the risk of electrical shock, and to assure proper operation, this fixture must be adequately grounded. To accomplish proper grounding, there must be a separate ground wire (green) contact between this fixture and the ground connection of your main power supply panel.
- This fixture is intended to be used for general indoor lighting in dry or damp locations.

### Assembly Instructions

#### Step 1 – Preparing for installation

- Disconnect electrical power** at the fuse or circuit breaker box before installing or servicing any part of this fixture.
- Carefully remove the fixture and hardware kit from the carton.
- Remove components from the hardware kit.
- Remove the canopy (1) from the fixture (7) by removing two barrel nuts (8) and detach the two hanging cables (5) from the hook location at the canopy side only. Carefully place the other half of the fixture to the side.
- Install the canopy (1) to the 3-0 or 4-0 junction box (not included) using two screws (2) to temporarily secure it. Mark two mounting holes for additional support. Take the canopy down and drill an appropriate hole at a marked location. Install plastic anchor (3 – not included) at drilled locations and remount the canopy using two screws (2) and (4 – not included) to secure it.
- The fixture is provided with 108" adjustable power cord and 60" stems (10) that can extend to 108" total drop with optional accessory. The stems included are four 12" long and two 6" long for a total of 60" long. Assemble stems (10) to one another as needed to achieve desired drop height then connect it to 90degree swivel (9). It is easier to feed fixture cord through each stem prior to connecting them together. Turn clockwise to tighten and secure it to the canopy. Carefully store excess cord using twist tie or zip tie (not included) to hide it inside the canopy. Repeat until all fixtures are installed.
- Re-attach the other half of the fixture (7) to the canopy (1) using two hanging cables (5) to temporarily secure it.

#### Wiring – All wiring must take place inside the junction box (not included)

**Caution:** Make sure power is off at the fuse or circuit breaker box. Check power wires for damage or scrapes. Use wire suitable for at least 90°C (194°F).

**Note:** Most dwellings built before 1985 have supply wire rated to 60°C. Consult a qualified electrician to ensure correct branch circuit conductor before installing.

#### Step 2 – Wiring fixture

- Make all wire connections to appropriate wire. Secure with wire nuts (provided).
- Connect the green wire from the fixture to the supply source ground wire.
- For non-dimming.** Connect the white wire from the fixture to the white (N) wire from the supply power source. Connect the black wire from the fixture to the black (L) wire from the supply power source. Pink and purple wires are not to be used and must be individually capped to prevent shorting.
- For TRIAC dimming.** Connect the white wire from the fixture to corresponding neutral (N) wire in accordance with the dimmer manufacturer instructions. Connect the black wire from the fixture to the corresponding control line (L) wire in accordance with the dimmer manufacturer instructions. Pink and purple wires are not to be used and must be individually capped to prevent shorting.
- For 0-10V dimming.** Connect the pink wire from the fixture to the dimmer source gray or pink wire. Connect the purple wire from the fixture to the dimmer source purple wire. Connect the white wire from the fixture to the neutral (N) wire from the dimming supply power source per dimmer wiring instructions. Connect the black wire from the fixture to the control line (L) wire from the dimmer supply power source per dimmer wiring instructions.
- Do not mix wires.** Pull on each wire lead to make sure connections are secure. Make certain no bare wires are exposed outside of wire connectors. Tuck all connections neatly into the junction box.

#### Step 3 – Color changing temperature adjustment, CCT (if desired)

- CCT switches are located inside the canopy. Adjust the switches to desired color temperature of 2700K, 3000K, 3500K, 4000K, or 5000K as shown below. Note: fixture is preset to 3000K from factory.

• 2700K
• 3000K
• 3500K
• 4000K
• 5000K

#### Step 4 – Mounting fixture

- Install the fixture (7) by aligning bottom holes to the threaded studs (6) using two barrel nuts (8) to secure it.

#### Step 5 – Install shade

- Install glass shades (12) to the hub (11) using decorative cap (13) and twist clockwise rotation until securely snug. Repeat until all shades are installed.

#### Step 6 – Restore power at the fuse or circuit breaker box

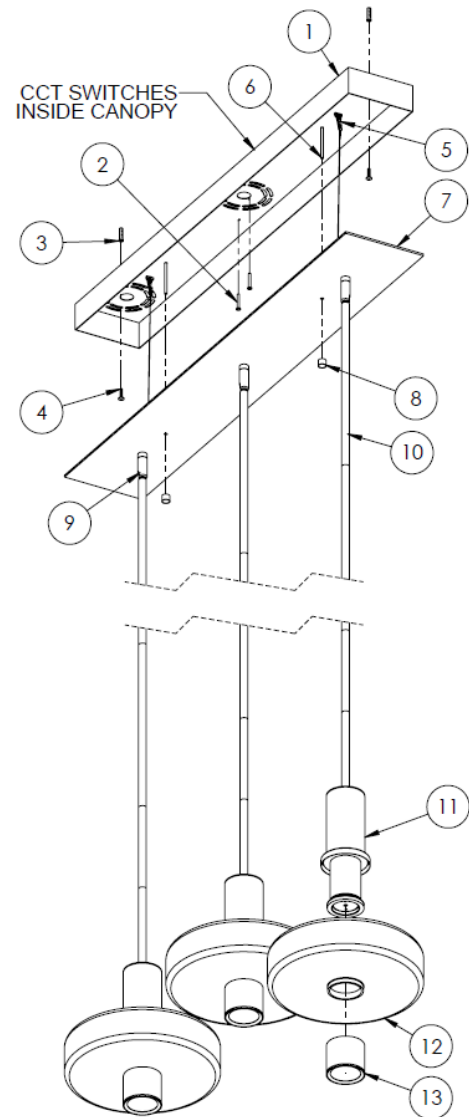

View shown for reference only. Individual models may vary.

#### Limited Factory Warranty

AFX Inc. hereby warrants that this fixture is free from defects in materials and workmanship when installed and used under normal operating conditions for a period of 5 years from date of purchase. This warranty covers all component parts and extends only to replacement of defective fixture or components; it does not cover failure due to improper installation, misuse, mishandling or damage incurred in transit.